



# VITAL

## USAGE AND MAINTENANCE MANUAL ELECTRIC SOLID TOP RANGES



> EST7010



> EST7020



> EST9010



> EST9020

## **PRESENTATION**

DEAR CUSTOMERS,

- To get the best yield of our products that are in compliance with the International Standards, we highly recommend you to read the user's manual and have it read to your users for long and continuous usages.
- This manual contains important informations about the secure installation, usage and maintenance of the product and necessary remarks to make the most efficient usage of your device.
- Keep this manual in an easily accessible and safe place to use when necessary.
- Our product is designed for heating and cooking food commodities. Any chemical or liquid substances or similar that can be in contact with the foodstuff, cannot be used for any heat treating that can cause damages for the health.
- The manufacturer cannot be held responsible for any damages from incorrect usage of the device, to people, the environment, or other materials resulting from translation or printing of this booklet.

# SYMBOLS AND THEIR MEANINGS



**READ THE USER MANUEL**

Before using the device, read the usage and maintenance manual carefully and keep it in an accessible place at all times.



**NOTE**

Information and tips to consider are indicated.



**WARNING**

Emphasizes the dangers that can cause injuries. Please follow carefully the instructions and pay attention to such situations.



**ELECTRICAL DANGER**

This icon draws attention to possible electrical dangers. Failure to follow the safety instructions may result in injury or death.



**GROUNDING**

Indicates that grounding is necessary.

# INDEX

- PRESENTATION ..... 1
- SYMBOLS AND THEIR MEANINGS ..... 2
- INDEX ..... 3
- SAFETY DETAILS ..... 4
- LABEL DETAILS ..... 5
- TECHNICAL SPECIFICATIONS ..... 6
- TRANSPORTATION, PLACEMENT AND READY TO INSTALL ..... 8
- PERSONEL PROTECTIVE EQUIPMENT ..... 9
- ELECTRICAL CONNECTION ..... 10
- USAGE ..... 11
- 1-) SWITCHING ON ..... 12
- 2-) SWITCHING OFF ..... 12
- CLEANING ..... 12
- MAINTENANCE AND MALFUNCTION ..... 13
- PROBLEMS AND SOLUTIONS ..... 13
- PERMANENT RISKS..... 14
- THINGS TO BE DONE FOR DAILY, MONTHLY AND ANNUAL MAINTENANCE OF THE MACHINE ..... 14
- WARRANTY CONDITIONS ..... 15
- OUT OF WARRANTY CASES ..... 16
- AUTHORIZED SERVICE START-UP PAGE ..... 17
- START UP PAGE ..... 17
- CONTACT ..... 18

## SAFETY DETAILS

- Do not expose the device to direct sunlight.
- Any kind of flammable or ignitable solid or liquid such as alcohol and derivatives, petro-chemical products, wood-plastic materials, curtains, clothes, etc. Should not be kept in the area of the device.
- This device must be installed in accordance with the current regulations and should only be used in a well-ventilated area.
- The instructions should be analysed before the installation and the usage of the device.
- It should not be interfered without the presence of the manufacturer or the authorized service.
- The device or its components cannot be used for any other purpose.
- Apart from the heating and the cooking of the food, it cannot be used as a heater for any purpose.
- The device cannot be left uncontrolled as long as it is on.
- Food compatible gloves must be used to protect hands from the overheating.
- In case of fire or flame in the area where the device is, switch off the safety net which is located in the main circuit connection and then use the fire extinguisher. Water should absolutely not be used, otherwise the flame will sprawl faster.
- Before the installation of the device, make sure that the connection rates (frequency, voltage, breaker) of the information tag of the device are corresponding with your electrical data.
- Never open the case of the device. The transmission of the electrical connection or the possible contact with the mechanical parts can be dangerous to you and may cause device malfunctions.
- The installation and the maintenance should be carried out by the qualified staff authorized by the manufacturer. Serious danger for the user can be arise due to incorrect installations, maintenances or repairs, and the manufacturer cannot be held responsible.
- Do not wash the device with pressurized water.



## LABEL DETAILS

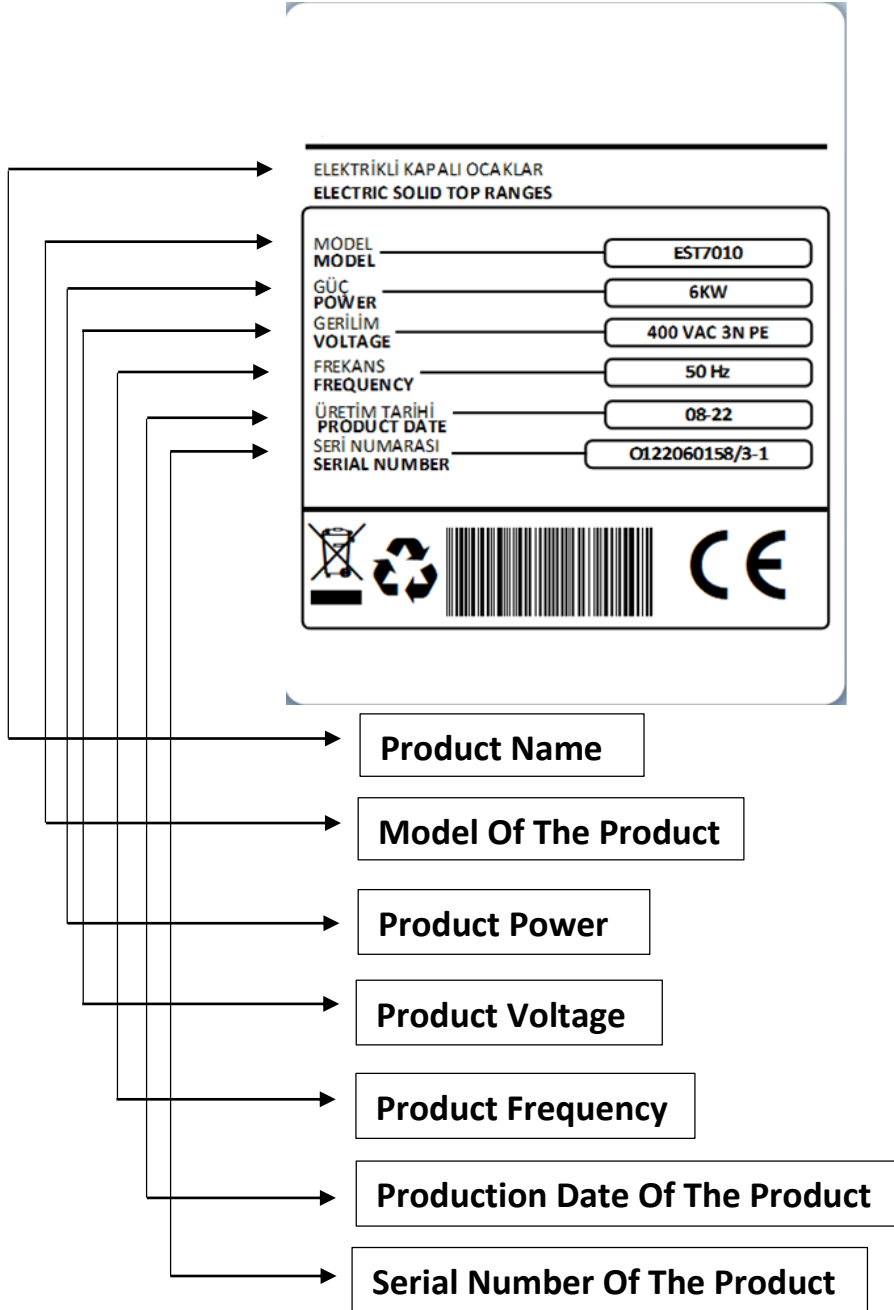

# TECHNICAL SPECIFICATIONS

PRODUCT CODE			EST7010	EST7020	EST9010	EST9020
DIMENSIONS (Mm)	A	WIDTH	400	400	800	800
	B	DEPTH	730	730	730	730
	C	HEIGHT	280	280	280	280
ELECTRIC POWER			6 kW	12 kW	8 kW	16 kW
ELECTRIC INLET			380-400 VAC 3N PE 50 HZ			
CABLE CROSS SECTION			5*2,5 mm <sup>2</sup>	5*2,5 mm <sup>2</sup>	5*2,5 mm <sup>2</sup>	5*4 mm <sup>2</sup>
WEIGHT			44 Kg	85 Kg	60 Kg	110 Kg

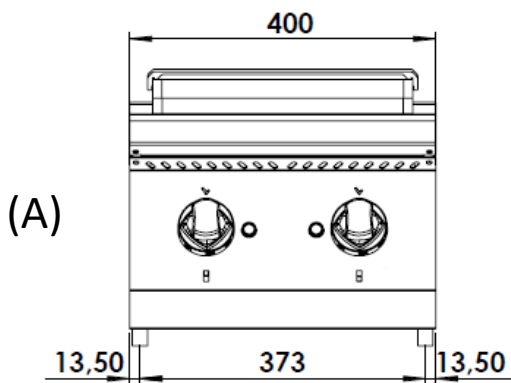

EST7010, EST9010

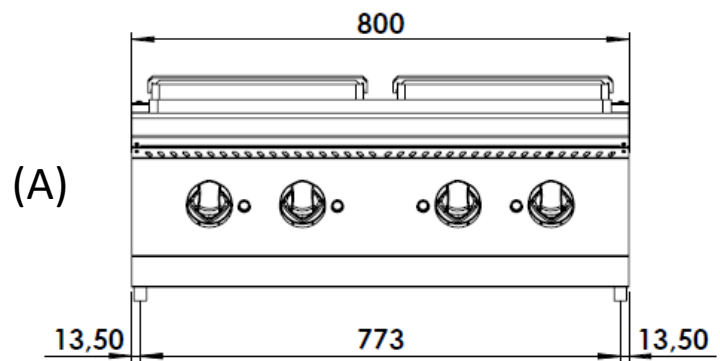

EST7020, EST9020

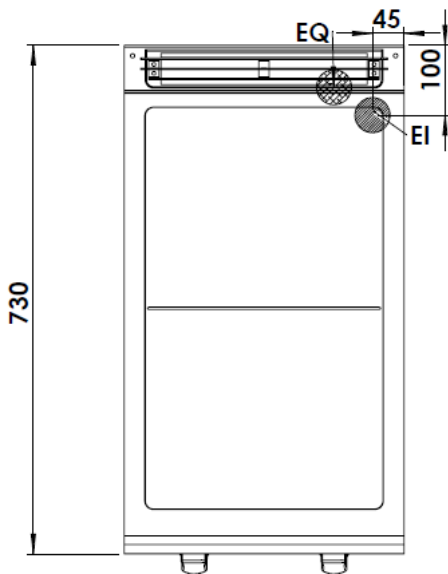

EST7010

(B)

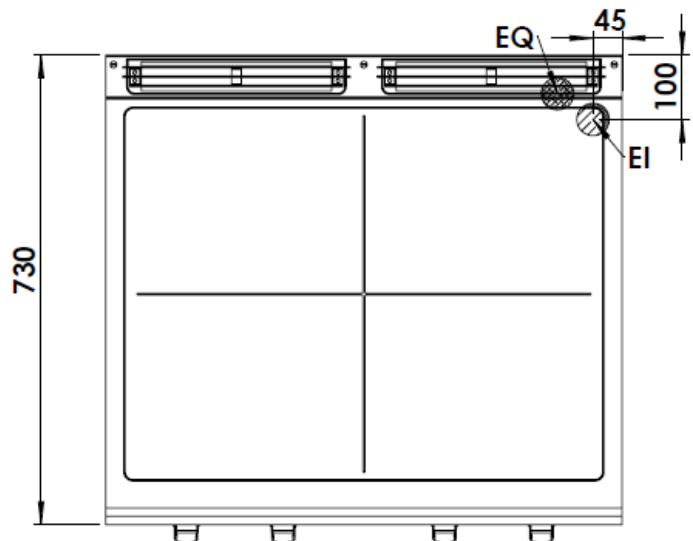

EST7020

(B)

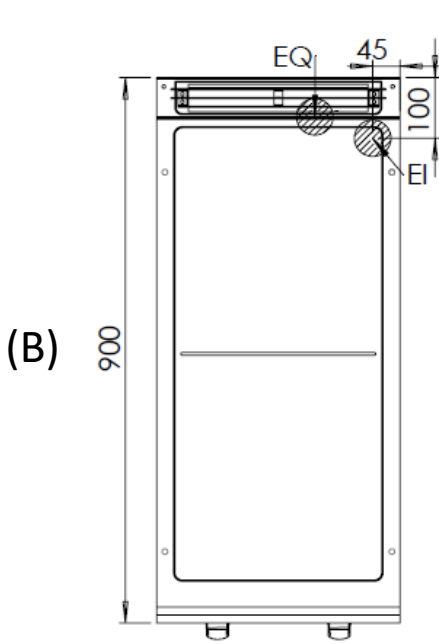

EST9010

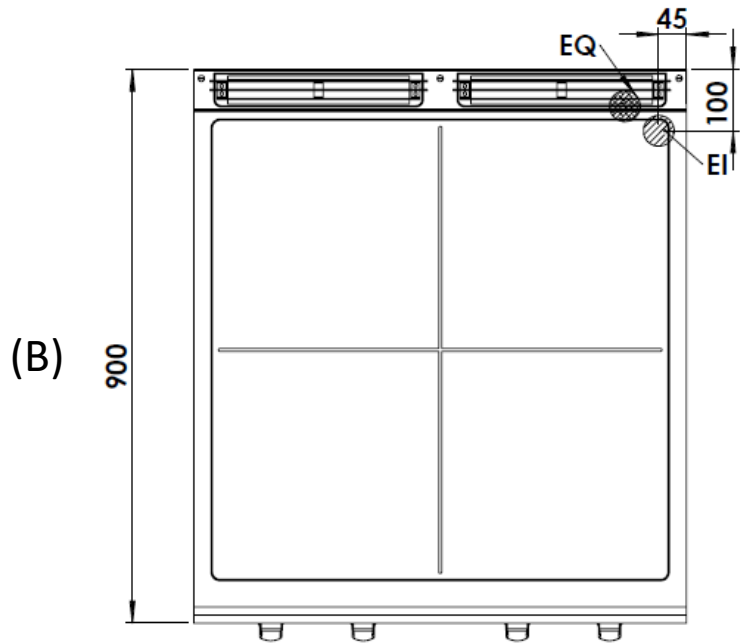

EST9020

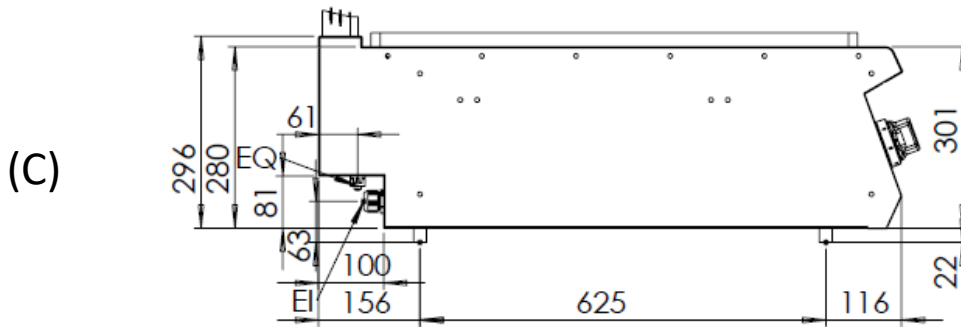

EST9010, EST9020

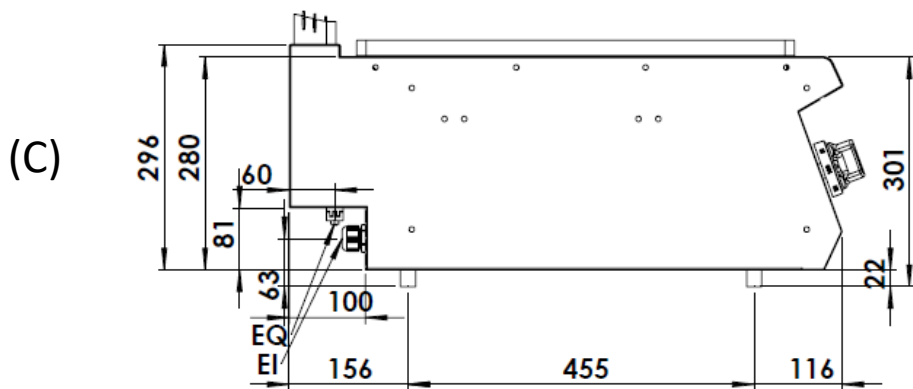

EST7010, EST7020

**NOTES**

**EQ=GROUND CONNECTION**

**EI=ELECTRIC CONNECTION**

## TRANSPORTATION, PLACEMENT AND READY TO INSTALL

- Do not tilt the device during the transportation, carry it upright.
- Use a suitable vehicle to avoid any kind of damages.
- Do not push or drag the device to bear.
- When transporting by pallet jack or forklift, make sure to not damage the device.
- Carry the device with its packaging until the installation area.
- It should be placed under a ventilation system to avoid any kind of bad smell that may occur during cooking process.
- It is recommended to place a suitable sized hood for the ventilation over the device without blocking the outlet of the chimney.
- In case the device is installed next to a wall, a partition, a kitchen furniture etc., make sure they are made by non flammable material or with a suitable thermal insulation coating with a margin of 10 cm, otherwise with a margin of 30 cm.
- Never place a combustible material on top of the device.
- Make a general cleaning before the first usage. You may use soapy water.
- The operating environment and the ventilation system of the device must be between 10°C to 40°C and have a maximum humidity level of %80.
- The device must be installed in accordance within the instructions.
- The protective film on the surface of the device must be stripped off carefully.



When you want to throw away the packaging, take into account the regulations in your country. Recycle usable packaging.



The device installed by the authorized service cannot be moved, connection hoses cannot be extended or changed except by the authorized service.

**PERSONEL PROTECTIVE EQUIPMENT**

Below are the personal protective equipment (PPE) for the operations during the machine's lifespan and the processes in which they will be used.

During normal daily use, the user must wear heat-resistant gloves to protect his hands. Life-threatening may occur if the equipment is not used in accordance with the procedures specified by the users.

	PROTECTIVE CLOTHING	PROTECTIVE SHOES	PROTECTIVE GLOVES	PROTECTIVE GLASSES	PROTECTIVE EARPHONES	PROTECTIVE MASK	PROTECTIVE HARD HAT
TRANSPORT		X	O				O
CARRYING		X	O				
UNPUCKING		X	O				
INSTALLATION		X	O				
DAILY USE	X	X	X				
PLACEMENT	O	X					
ROUTINE CLEANING	O	X	X	X			
SPECIAL CLEANING	O	X	X	X			
MAINTENANCE	O	X					
DISASSEMBLY	O	X					

**O= IT SHOULD BE USED WHEN NECESSARY.**  
**X=MUST BE USED PRECISELY.**

## ELECTRICAL CONNECTION

- Technical specification section should be analysed for the appropriate cable to be used for the electrical connection of the device.
- The electrical supply circuit must be done by the authorized staff. Before installation, make sure that your fitment meets the requirements. The device should absolutely not be used without grounding.
- The electrical voltage must be stable for the proper fonction of the device. If the malfunction is caused by the voltage, the replacement of these parts are considered “out of warranty”. Fault detection is based on the service declaration.
- To prevent the device from any short circuit and overcurrent, the device must be supplied with the appropriate fuse control.

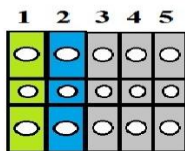

1 -   
 2 - NÖTR  
 3 - L1  
 4 - L2  
 5 - L3



### GROUNDING

Grounding is required.



### ELECTRICAL DANGER

There is an electrical hazard. If necessary precautions are not taken, injury and death may occur.

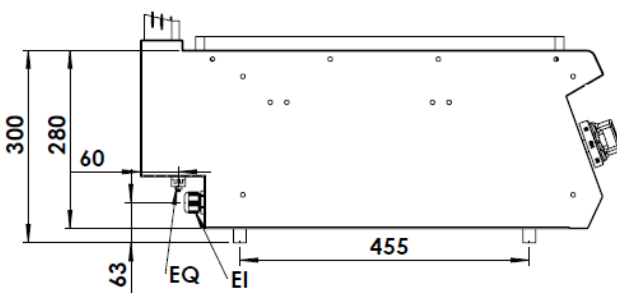

EST7010, EST7020

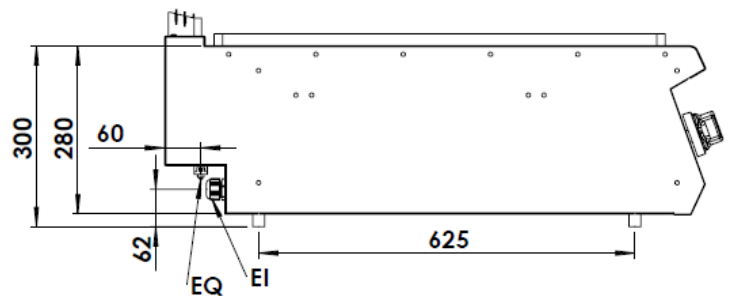

EST9010, EST9020

EQ=GROUNDING CLAMP

EI=ELECTRIC INLET

## USAGE

- The device is designed for professional usage and should only be used by trained personnel.
- Do not touch the hot parts of the device.
- If the device is operated as ungear for a while, it will remove the smoke caused by the protective oils.
- Clean the surface of the device before cooking process.
- Control the waste oil container after the cooking process.

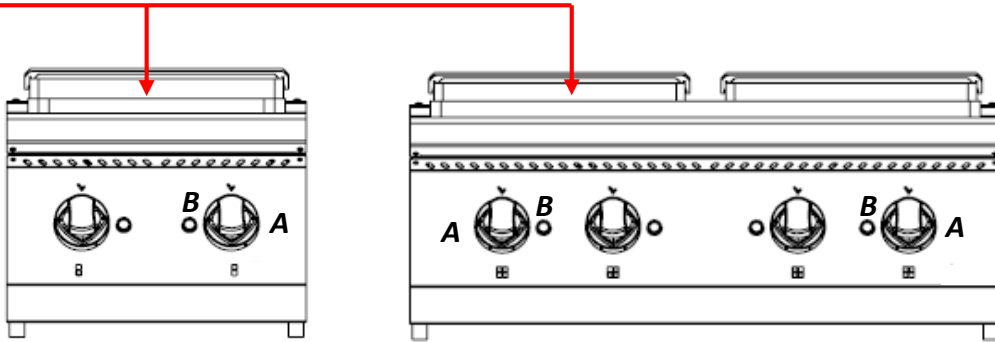

Şekil-1 Control Panel

A	Thermostat Button
B	Thermostat Lamp



Attention! Hot surface may cause burns and injuries.



**READ THE USER MANUAL**

Before you start using the device, read the usage and maintenance manual carefully. Keep it somewhere you can always reach it.

### 1-) Switching On

- Turn on the main circuit connection to give electricity to the device.
- Turn the thermostat button to the required level. The thermostat lamp will light and the heating will start.
- When it reaches the required temperature, the lamp will turn off and the heating will stop.

### 2-) Switching Off

- Set the thermostat button to the “0” position. The lamp will turn off and the heating process will stop.
- When the cooking process is over, turn off the power of the device for your own safety.

## CLEANING

- Disconnect the wiring before starting the cleaning process.
- When cleaning the device, make sure to prevent water from entering the electrical parts.
- Do not wash the device with high pressure water.
- After each usage, clean the device with a cloth dipped in warm soapy water.
- Do not use abrasive detergent or wire brushes when cleaning the device’s surface.
- Clean completely the device on specific periods with convenient cleaning materials.



Read the instructions before turning the device on and off.

## MAINTENANCE AND MALFUNCTION

- The maintenance and the malfunction of the device must be carried out by authorized service or by a personnel assigned by the manufacturer.
- All connections and repairs must be carried out by the authorized service centers, otherwise, your device will be out of warranty.

### Problems and Solutions

Range do not heat up.	<ol style="list-style-type: none"><li>1. Check the fuse to which the device is connected.</li><li>2. Check the commutator switch position.</li><li>3. If the plates do not heat up after these steps, please contact the <b><u>AUTHORIZED SERVICE.</u></b></li></ol>
Temperature is not adjustable.	Contact the <b><u>AUTHORIZED SERVICE.</u></b>



#### NOTE

Please contact the authorized service in case of malfunction.

# PERMANENT RISKS

The machine has certain risks that cannot be eliminated by design or by the installation of adequate protection devices. Permanent risks are listed below for full customer information. It is therefore strictly forbidden to do it within these risks.

PERMANENT RISKS	EXPLANATION
Slip and Fall	The technician may slip and fall due to dirt and water on the floor.
Burns	It occurs when the technician consciously or unconsciously touches the area with a hot surface warning and works without gloves.
Electric shock	It occurs due to maintenance without cutting off the electricity and placing the product on a wet floor.

# THINGS TO BE DONE FOR DAILY, MONTHLY AND ANNUAL MAINTENANCE OF THE MACHINE

<p><b>DAILY</b></p> <p>1) General cleaning of the machine and the surrounding area is required.</p> <p><b>MONTHLY</b></p> <p>1) Parts of the devices should be checked, loosened and deformed ones should be tightened or replaced.</p> <p><b>YEARLY</b></p> <p>1) Mechanical parts should be checked for breakage and deformation.</p> <p>2) The legibility of labels and symbols should be checked.</p> <p>3) Connection cable and plug are damaged, rotten, broken, etc. Things should be checked for.</p>
---

## **WARRANTY CONDITIONS**

- According to the consumer rights law and commercial law of the Ministry of Industry, except in a special case of agreement, sold industrial products by our company has one (1) year of warranty and that period starts from the delivery date of the product.
- The warranty includes all the components of the device against fabrication or faulty workmanship, eliminations of the problems or malfunctions of the device caused by the workmanship and installation errors, replacement of non-repairable parts or the mending of repaired parts that can be reused. It also includes repairings or changes of the components by the authorized personnel, or the labor fee due to the problem under the warranty.
- In order for the warranty conditions to be valid, the maintenance of the components fixed to the device, the maintenance of the product, as indicated in the user's manual, should be done yearly and montly and the information form must be held after the maintenance to be presented when required.
- The document of the replacement of the component has to be presented for parts warranty claims.
- In order to continue the warranty period, the paid periodic maintenance has to be done by the authorized service and the information form must be held to be presented when required.
- In case of any malfunctions under the warranty period, the time spent in the repairment of the device is added to the warranty period. The repair can be maximum 30 (thirty) days. This period starts when the device is on the service station. In case of the absence of this station, the period will start when the manufacturer or the importer is notified by the product seller.
- In accordance with the regulations of the warranty document implementation fundamentals published by the Ministry of Industry, the warranty deed of the industrial products are the purchase invoices.
- If there is any kind of malfunctions due to both the materail and the workmanship, or assembly faults under the warranty period, the necessary replacement and reparing will be done by our authorized personnel without any charge.

## OUT OF WARRANTY CASES

- If the product is used above its intended purpose, standards or capacity specified by the manufacturer,
- In case of the bad locationing of the product, continuous usage and unhealthy environment (ex: required ventilation), not suitable floor or flat platform, not using a suitable cable, a proper voltage or a grounding,
- If the product hasn't been used as explained in the instruction manual,
- If the fault is caused by inconvenient, wrong or careless usage,
- If the malfunction is caused by fluctuations in the mains power, a stroke or a meteor lightning, a fire, a flood, an earthquake or similar cases,
- If the special tools and equipments installed or the maintenance and repair are made by any other person than the authorized person,
- When requesting a service, if the installation-start documents or purchase invoices of the product are not presented,
- If the informations on the documents of the installation, start or maintenance has been destroyed or changed,
- If the paid annual or the contractual periodic maintenance of the product has not been done on time by the authorized personnel,
- If unoriginal spare parts have been used,
- Notifications to our authorized services under the warranty period about the malfunctions that could not have been repaired, will make the time-out of the warranty stop only for that specific malfunction. In this case, the authorized service will inform about the compensation or the non-troubleshooting and the expanded warranty period will end in 3 months in any cases,
- Damages caused by the unnecessary loss of time, the maleficence, the revenue loss, or the conduction of the product from the defective location to another,
- Malfunctions of the product due to squalidity are not covered by the warranty,
- The methods to be followed about the fault detection and elimination are determined completely by MUTAŞ's technical service management and the service matter is taken as basis for the determination of the malfunction.

## AUTHORIZED SERVICE START-UP PAGE

### Start Up Page

- The model and serial number of your device are shown on the “Technical Data” label affixed to the device.
- Select the technical data according to the device model on the nameplate.

### MUST BE FILLED BY AUTHORIZED SERVICE!

<b>COMPANY INFORMATIONS</b>	:	
<b>PRODUCT</b>	:	
<b>MODEL</b>	:	
<b>SERIAL NUMBER</b>	:	
<b>PRODUCTION DATE</b>	:	
<b>SERVICE STAMP AND SIGNATURE</b>	:	
<b>PERSONNEL OF THE SERVICE</b>	:	
<b>CONTACT</b>		
<b>PHONE</b>	:	<b>0312 837 76 72</b>
<b>FAX</b>	:	<b>0312 837 73 38</b>
<b>E-MAIL</b>	:	<b>teknikservis@vitalmutfak.com</b>

## CONTACT

**MUTAŞ ENDÜSTRİYEL MUTFAK SANAYİ TİCARET ANONİM ŞİRKETİ**  
**HEADQUARTER**

**ADRESS: Plevne Cad. No:40 Gülveren / ANKARA**

**PHONE: (0312) 363 99 33 FAX: (0312) 363 94 92**

**Web: [www.vitalmutfak.com](http://www.vitalmutfak.com) E-Mail: [info@vitalmutfak.com](mailto:info@vitalmutfak.com)**

**MUTAŞ ENDÜSTRİYEL MUTFAK SANAYİ TİCARET ANONİM ŞİRKETİ**  
**FACTORY**

**ADRESS: Taşpınar Mahallesi Küme Evleri No:154/A 06760**  
**Çubuk / ANKARA-TURKEY**

**PHONE: (0312) 837 76 72 FAX: (0312) 837 73 38**

**Web: [www.vitalmutfak.com](http://www.vitalmutfak.com)**  
**E-Mail: [info@vitalmutfak.com](mailto:info@vitalmutfak.com)**

## AFTER SALES SERVICE

For the nearest MUTAŞ/VİTAL Authorized Service, please  
contact the numbers above.

[info@vitalmutfak.com](mailto:info@vitalmutfak.com)

