



VITAL

USAGE AND MAINTENANCE MANUAL GAS BAIN-MARIE



> GSB7010



> GSB7020



> GSB9010



> GSB9020

PRESENTATION

DEAR CUSTOMERS,

- To get the best yield of our products that are in compliance with the International Standards, we highly recommend you to read the user's manual and have it read to your users for long and continuous usages.
- This manual contains important informations about the secure installation, usage and maintenance of the product and necessary remarks to make the most efficient usage of your device.
- Our product is designed for heating and cooking food commodities. Any chemical or liquid substances or similar that can be in contact with the foodstuff, cannot be used for any heat treating that can cause damages for the health.
- The manufacturer cannot be held responsible for any damages from incorrect usage of the device, to people, the environment, or other materials resulting from translation or printing of this booklet.

SYMBOLS AND THEIR MEANINGS



READ THE USER MANUEL

Before using the device, read the usage and maintenance manual carefully and keep it in an accessible place at all times.



NOTE

Information and tips to consider are indicated.



WARNING

Emphasizes the dangers that can cause injuries. Please follow carrefully the instructions and pay attention to such situations.



GAS DANGER

Have your maintenance and checks done against possible gas dangers.

INDEX

- PRESENTATION 1
- SYMBOLS AND THEIR MEANINGS..... 2
- INDEX..... 3
- SAFETY DETAILS 4
- LABEL DETAILS 5
- TECHNICAL SPECIFICATIONS..... 6
- TRANSPORTATION, PLACEMENT AND READY TO INSTALL..... 10
- PERSONEL PROTECTIVE EQUIPMENT 11
- GAS CONNECTION 12
- USAGE..... 13
- 1-) SWITCHING ON 14
- 2-) SWITCHING OFF 14
- CLEANING 14
- MAINTENANCE AND MALFUNCTION 15
- PROBLEMS AND SOLUTIONS 15
- PERMANENT RISKS 16
- THINGS TO BE DONE FOR DAILY, MONTHLY AND ANNUAL MAINTENANCE OF THE MACHINE 16
- WARRANTY CONDITIONS 17
- OUT OF WARRANTY CASES..... 18
- AUTHORIZED SERVICE START-UP PAGE..... 19
- START UP PAGE 19
- CONTACT 20

SAFETY DETAILS

- Do not expose the device to direct sunlight.
- Any kind of flammable or ignitable solid or liquid such as alcohol and derivatives, petro-chemical products, wood-plastic materials, curtains, clothes, etc. Should not be kept in the area of the device.
- This device must be installed in accordance with the current regulations and should only be used in a well-ventilated area.
- The instructions should be analysed before the installation and the usage of the device.
- The device is designed for professional usage and should only be used by trained personnel.
- It should not be interfered without the presence of the manufacturer or the authorized service.
- The device or its components cannot be used for any other purpose.
- Apart from the heating and the cooking of the food, it cannot be used as a heater for any purpose.
- The device cannot be left uncontrolled as long as it is on.
- Food compatible gloves must be used to protect hands from the overheating.
- In case of fire or flame in the area where the device is, switch off the safety net which is located in the main circuit connection and then use the fire extinguisher. Water should absolutely not be used, otherwise the flame will sprawl faster.
- The installation and the maintenance should be carried out by the qualified staff authorized by the manufacturer. Serious danger for the user can be arise due to incorrect installations, maintenances or repairs, and the manufacturer cannot be held responsible.
- Do not wash the device with pressurized water.



LABEL DETAILS

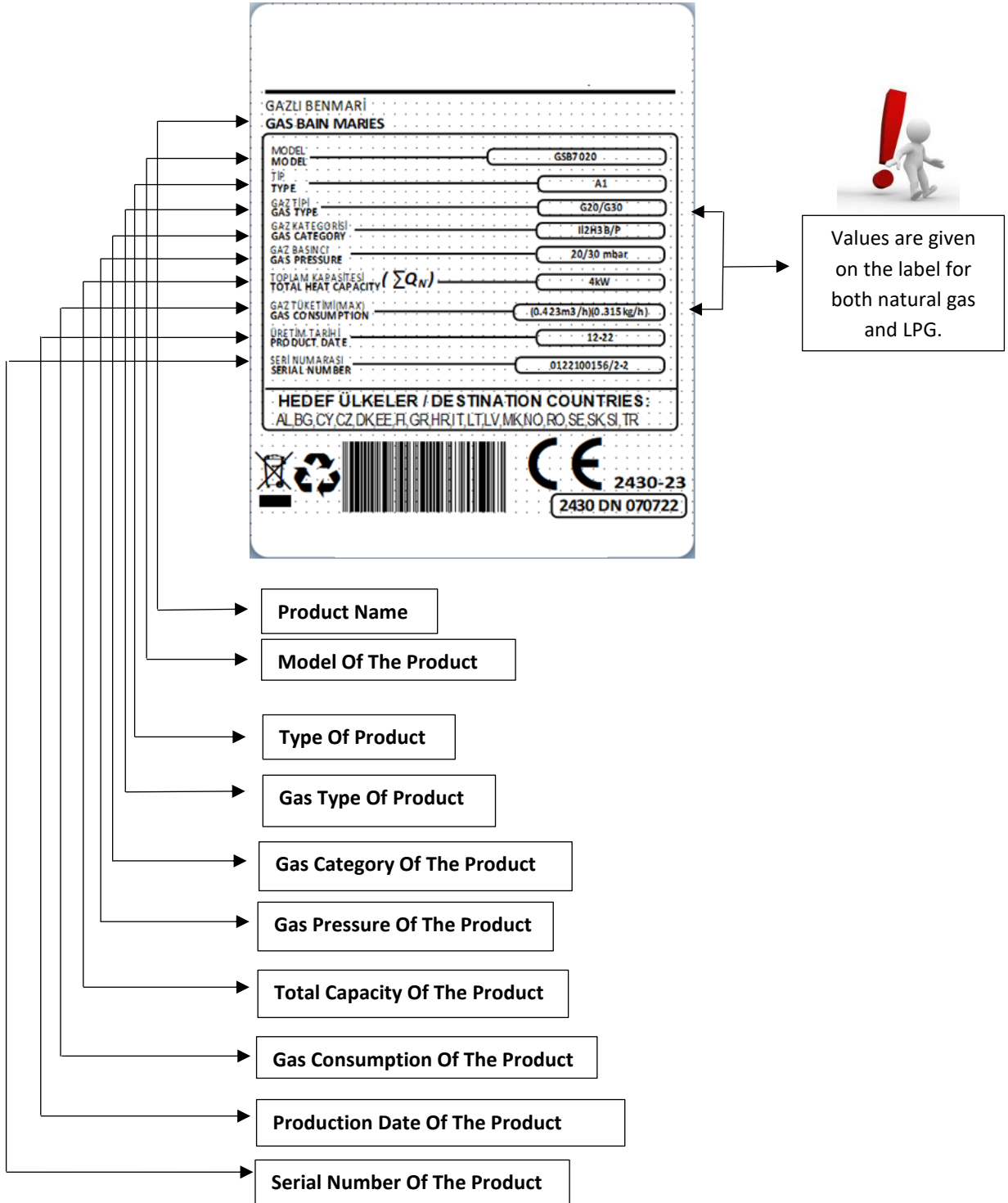

TECHNICAL SPECIFICATIONS

PRODUCT CODE			GSB7010	GSB7020	GSB9010	GSB9020		
DIMENSIONS (Mm)	A	WIDTH	400	800	400	800		
	B	DEPTH	730	730	900	900		
	C	HEIGHT	280	280	280	280		
GAS CONNECTION		G-20 (NG)	1/2"	1/2"	1/2"	1/2"		
		G-30 (LPG)	1/2"	1/2"	1/2"	1/2"		
GAS CONSUMPTION		G-20 (NG)	MAXIMUM	0,212m ³ /h	0,423m ³ /h	0,212m ³ /h	0,423m ³ /h	
			MINIMUM	0,111m ³ /h	0,222m ³ /h	0,111m ³ /h	0,222m ³ /h	
		G-30 (LPG)	MAXIMUM	0,158 kg/h	0,315 kg/h	0,158kg/h	0,315kg/h	
			MINIMUM	0,083kg/h	0,166 kg/h	0,083kg/h	0,166kg/h	
COUNTRY	AL, BG, CY, CZ, DK, EE, FI, GR, HR, IT, LT, LV, MK, NO, RO, SE, SK, SI, TR	GAS PRESSURE	NOMINAL	G-20 (NG)	20 mbar	20 mbar	20 mbar	20 mbar
				G-30 (LPG)	30 mbar	30 mbar	30 mbar	30 mbar
		MAXIMUM	G-20 (NG)	25 mbar	25 mbar	25 mbar	25 mbar	
			G-30 (LPG)	35 mbar	35 mbar	35 mbar	35 mbar	
		MINIMUM	G-20 (NG)	17 mbar	17 mbar	17 mbar	17 mbar	
			G-30 (LPG)	25 mbar	25 mbar	25 mbar	25 mbar	
	INJECTOR	G-20 (NG)	0.9 mm	0.9 mm	0.9 mm	0.9 mm		
		G-30 (LPG)	0.7 mm	0.7 mm	0.7 mm	0.7 mm		
GAS CATEGORY		II ₂ H ₃ B/P						
TOTAL HEAT CAPACITY ($\sum Q_N$)		G-20 (NG)	2 kW	4 kW	2 kW	4 kW		
		G-30 (LPG)	4 kW	8 kW	4 kW	8 kW		
WEIGHT		23 Kg	39 Kg	22 Kg	45 Kg			

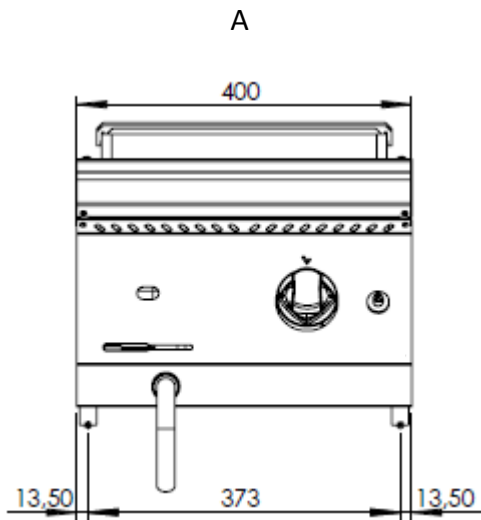

GSB7010, GSB9010

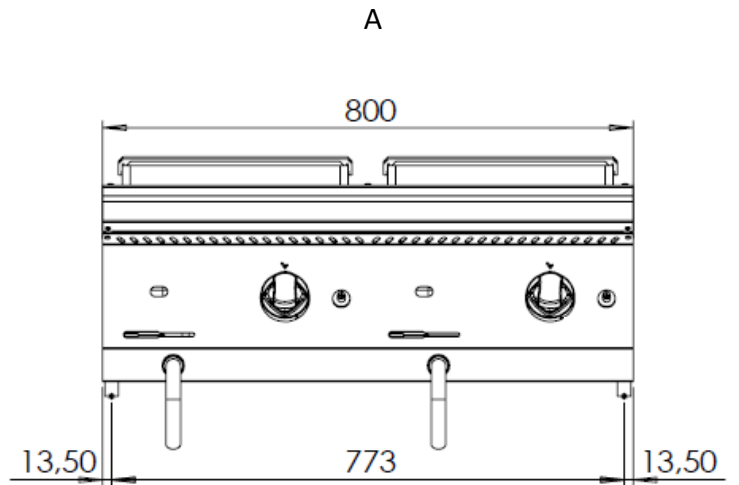

GSB7020, GSB9020

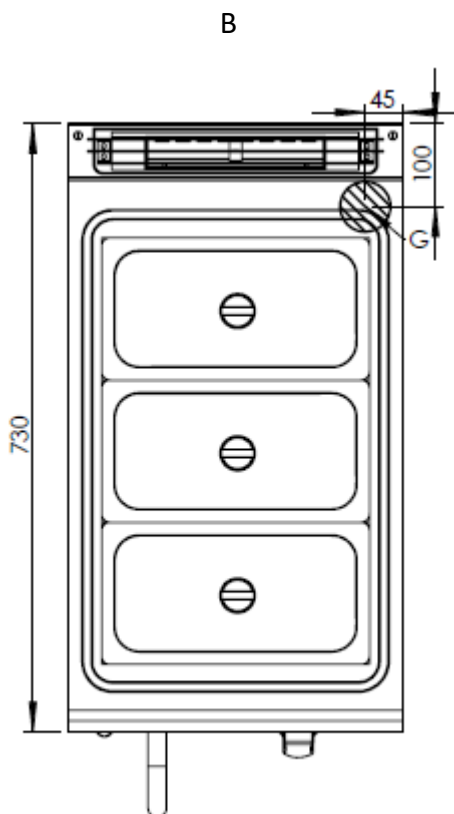

GSB7010

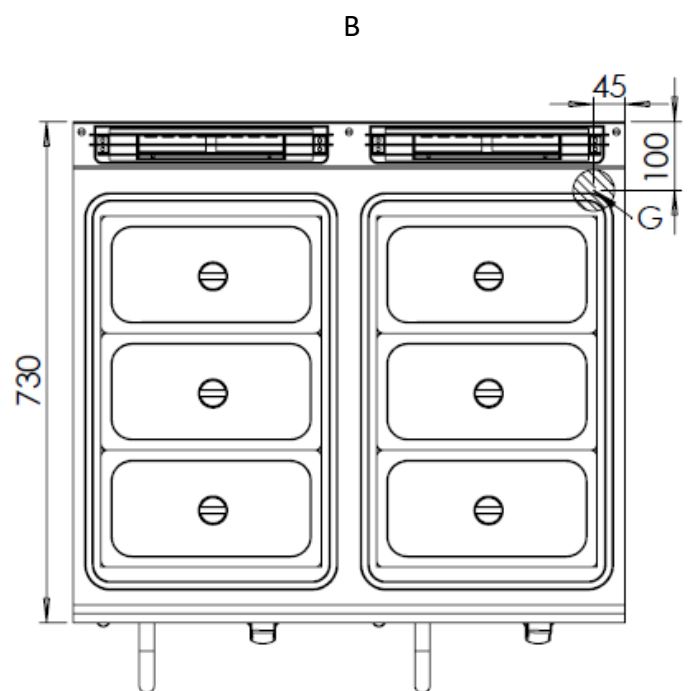

GSB7020

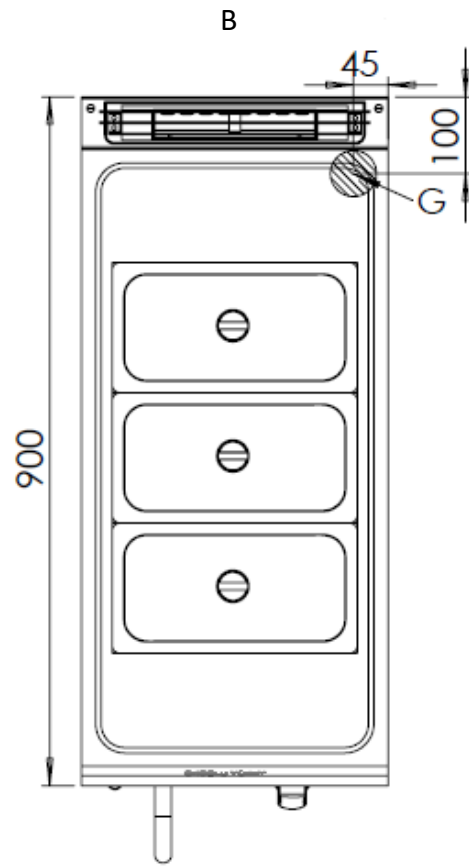

GSB9010

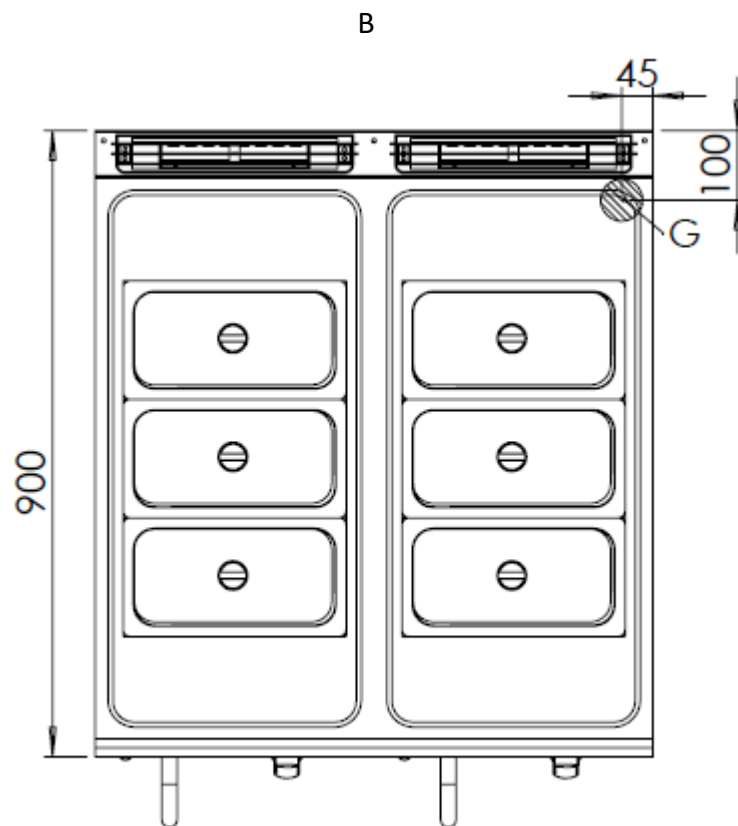

GSB9020

C

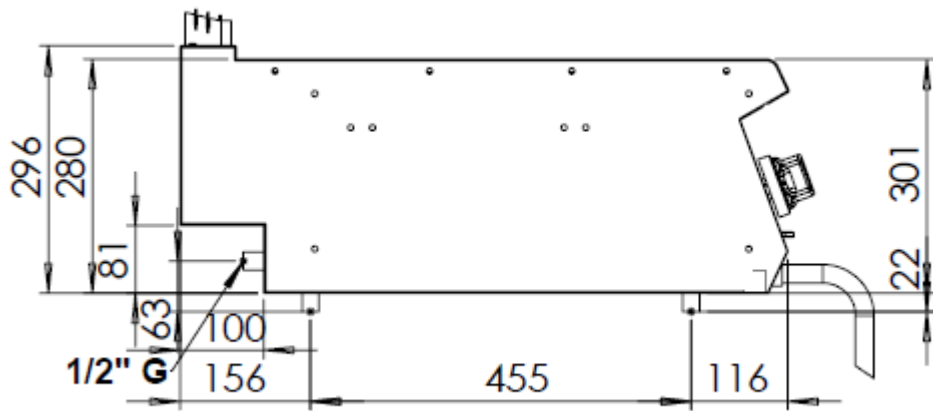

GSB7010,
GSB7020, GSB7030

C

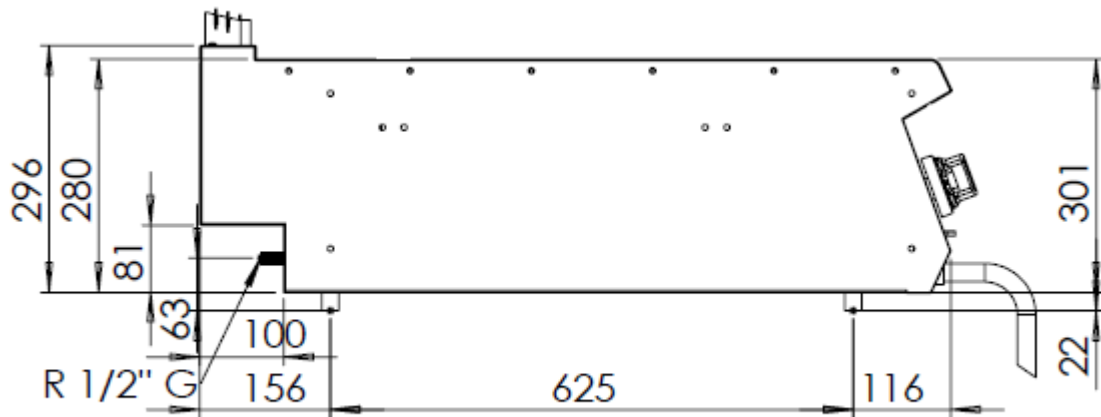

GSB9010, GSB9020,
GSB9030

TRANSPORTATION, PLACEMENT AND READY TO INSTALL

- Do not tilt the device during the transportation, carry it upright.
- Use a suitable vehicle to avoid any kind of damages.
- Do not push or drag the device to bear.
- When transporting by pallet jack or forklift, make sure to not damage the device.
- Carry the device with its packaging until the installation area.
- It should be placed under a ventilation system to avoid any kind of bad smell that may occur during cooking process.
- It is recommended to place a suitable sized hood for the ventilation over the device without blocking the outlet of the chimney.
- In case the device is installed next to a wall, a partition, a kitchen furniture etc., make sure they are made by non flammable material or with a suitable thermal insulation coating with a margin of 10 cm, otherwise with a margin of 30 cm.
- Never place a combustible material on top of the device.
- Make a general cleaning before the first usage. You may use soapy water.
- The operating environment and the ventilation system of the device must be between 10°C to 40°C and have a maximum humidity level of %80.
- The device must be installed in accordance within the instructions.
- The protective film on the surface of the device must be stripped off carefully.
- Convenient gas connection with the required technical specifications must be installed in the area of the device.



When you want to throw away the packaging, take into account the regulations in your country. Recycle usable packaging.



The device installed by the authorized service cannot be moved, connection hoses cannot be extended or changed except by the authorized service.

PERSONEL PROTECTIVE EQUIPMENT

Below are the personal protective equipment (PPE) for the operations during the machine's lifespan and the processes in which they will be used.

During normal daily use, the user must wear heat-resistant gloves to protect his hands. Life-threatening may occur if the equipment is not used in accordance with the procedures specified by the users.

	PROTECTIVE CLOTHING	PROTECTIVE SHOES	PROTECTIVE GLOVES	PROTECTIVE GLASSES	PROTECTIVE EARPHONES	PROTECTIVE MASK	PROTECTIVE HARD HAT
TRANSPORT		X	O				O
CARRYING		X	O				
UNPUCKING		X	O				
INSTALLATION		X	O				
DAILY USE	X	X	X				
PLACEMENT	O	X					
ROUTINE CLEANING	O	X	X	X			
SPECIAL CLEANING	O	X	X	X			
MAINTENANCE	O	X					
DISASSEMBLY	O	X					

O= IT SHOULD BE USED WHEN NECESSARY.
X=MUST BE USED PRECISELY.

GAS CONNECTION

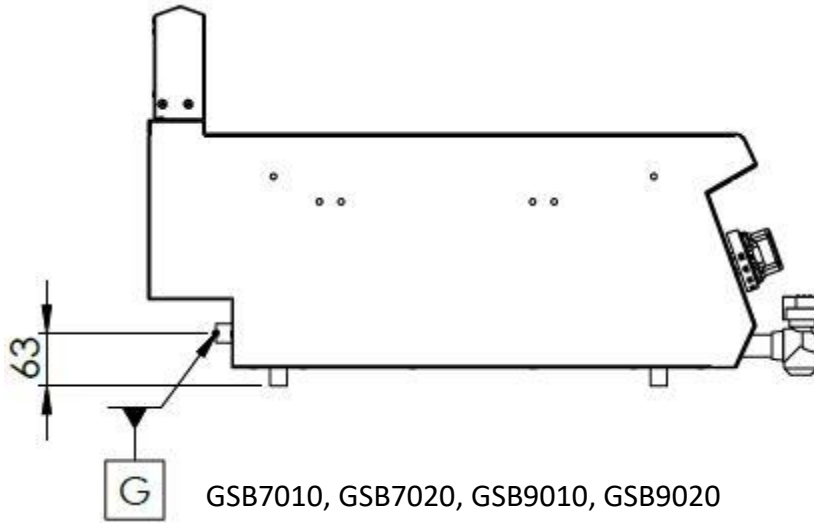

G= GAS INLET



GAS DANGER

Have your maintenance and checks done against possible gas dangers.

- Convenient gas fittings must be done as written on the product tag.
- Gas pressure corresponding to the gas type as stated on the technical specifications, should be adjusted using the appropriate regulator capacity.
- An appropriate EN 331 Standard valve must be used before the gas inlet of the device.
- The gas connection must be done according to EN 14800 Standards, with a maximum length of 120 cm metal hose.
- Check the gas leakage with a foamy water or a gas leak detector. In case of leakage (foaming will occur on the foamy part or the gas leak detector will give a warning signal), do not use fire, and consult your seller.
- If the device is connected to a gas installation, the inlet of the gas should be designed to not reduce the gaseous flow rate.

USAGE

- The device is designed for professional usage and should only be used by trained personnel.
- Close the valve before filling water.
- Do not use the device over the capacity specified in the technical specifications.
- Do not operate the device when the water tank is empty.

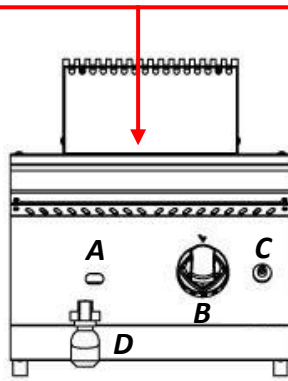

GSB7010, GSB9010

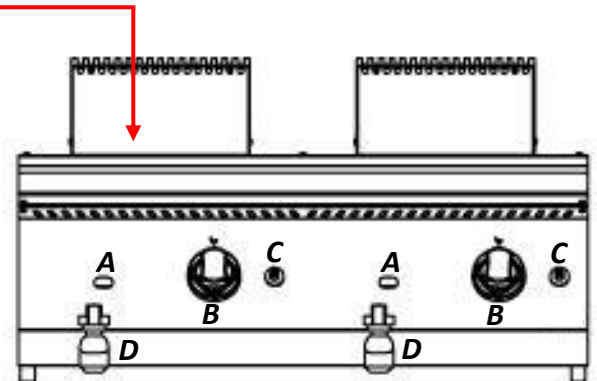

GSB7020, GSB9020

	Ignition Position
	Maximum Flame Position
	Low Flame Position
	Off Position of the Control Knob

A	Observation Port
B	Gas Control Knob
C	Ignition Button
D	Waste Oil Container



Attention! Hot surface may cause burns and injuries.

1-) Switching On

- Turn on the gas valve linked to the device.
- Lightly press the desired section's gas control knob and turn it to counter clockwise to bring it to the ignition position.
- Press and hold flame to the pilot burner at the same time as the gas control knob is at the ignition position (size of a lighter's flame) for the flame ignition.
- When the pilot burner ignites, retract the approached flame and hold the control knob down for about 10 seconds. Then, the burner will continue the ignition.
- If the pilot burner continues the ignition, turn the gas control knob counter clock wise to the maximum flame level. For a lower flame, turn the knob to the minimum flame level.

2-) Switching Off

- Turn off the gas control knob to shut the burner off.
- Turn off the main gas valve of the device when not using it to prevent any possible gas leakage.

CLEANING

- Do not wash the device with high pressure water.
- Disconnect the device from the gas before cleaning.
- After each operation, clean the device with a cloth dipped in warm soapy water.
- Do not use abrasive detergent or wire brushes when cleaning the device's surface.



Read the instructions before turning the device on and off.

MAINTENANCE AND MALFUNCTION

- The maintenance and the malfunction of the device must be carried out by authorized personnel or by a personnel assigned by the manufacturer.
- All connections and repairs must be carried out by the authorized service centers, otherwise, your device will be out of warranty.

Problems and Solutions

PROBLEM	SOLUTION
The device does not ignite the burners.	Turn on the gas valve of the local gas network or the LPG gas tube.
Burners have low ignition.	Check the compatibility of your device's gas type and pressure indicated on the product tag with the supplied gas type. If they are not compatible, please contact the AUTHORIZED SERVICE .
The ignition of the burners is not permanent.	There is a problem with the flame arrester fitting. Please contact the AUTHORIZED SERVICE .
The ignition of the burner is not permanent on low level flame.	The low ignition level of the burner is not adjusted. Please contact the AUTHORIZED SERVICE .
A gas smell around the device is detected or the leak detectors are giving warning signals.	Turn off the gas valve and IMMEDIATELY contact the AUTHORIZED SERVICE .
Cihaz etrafında gaz kokusu hissedilmesi veya gaz dedektörlerinin ikaz vermesi	Cihaza ait gaz vanasını kapatarak derhal YETKİLİ SERVİS ile irtibata geçiniz.



NOTE

Please contact the authorized service in case of malfunction.

PERMANENT RISKS

The machine has certain risks that cannot be eliminated by design or by the installation of adequate protection devices. Permanent risks are listed below for full customer information. It is therefore strictly forbidden to do it within these risks.

PERMANENT RISKS	EXPLANATION
Slip and Fall	The technician may slip and fall due to dirt and water on the floor.
Burns	It occurs when the technician consciously or unconsciously touches the area with a hot surface warning and works without gloves.
Electric shock	It occurs due to maintenance without cutting off the electricity and placing the product on a wet floor.

THINGS TO BE DONE FOR DAILY, MONTHLY AND ANNUAL MAINTENANCE OF THE MACHINE

<p>DAILY</p> <p>1) General cleaning of the machine and the surrounding area is required.</p> <p>MONTHLY</p> <p>1) Parts of the devices should be checked, loosened and deformed ones should be tightened or replaced.</p> <p>YEARLY</p> <p>1) Mechanical parts should be checked for breakage and deformation.</p> <p>2) The legibility of labels and symbols should be checked.</p> <p>3) Connection cable and plug are damaged, rotten, broken, etc. Things should be checked for.</p>

WARRANTY CONDITIONS

- According to the consumer rights law and commercial law of the Ministry of Industry, except in a special case of agreement, sold industrial products by our company has one (1) year of warranty and that period starts from the delivery date of the product.
- The warranty includes all the components of the device against fabrication or faulty workmanship, eliminations of the problems or malfunctions of the device caused by the workmanship and installation errors, replacement of non-repairable parts or the mending of repaired parts that can be reused. It also includes repairings or changes of the components by the authorized personnel, or the labor fee due to the problem under the warranty.
- In order for the warranty conditions to be valid, the maintenance of the components fixed to the device, the maintenance of the product, as indicated in the user's manual, should be done yearly and montly and the information form must be held after the maintenance to be presented when required.
- The document of the replacement of the component has to be presented for warranty claim parts.
- In order to continue the warranty period, the paid periodic maintenance has to be done by the authorized service and the information form must be held to be presented when required.
- In case of any malfunctions under the warranty period, the time spent in the repairment of the device is added to the warranty period. The repair can be maximum 30 (thirty) days. This period starts when the device is on the service station. In case of the absence of this station, the period will start when the manufacturer or the importer is notified by the product seller.
- In accordance with the regulations of the warranty document implementation fundamentals published by the Ministry of Industry, the warranty deed of the industrial products are the purchase invoices.
- If there is any kind of malfunctions due to both the materail and the workmanship, or assembly faults under the warranty period, the necessary replacement and repairing will be done by our authorized personnel without any charge.

OUT OF WARRANTY CASES

- If the product is used above its intended purpose, standards or capacity specified by the manufacturer,
- In case of the bad locationing of the product, continuous usage and unhealthy environment (ex: required ventilation), not suitable floor or flat platform, lack of convenient gas pressure,
- If the product hasn't been used as explained in the instruction manual,
- If the fault is caused by inconvenient, wrong or careless usage,
- If the special tools and equipments installed or the maintenance and repair are made by any other person than the authorized person,
- When requesting a service, if the installation-start documents or purchase invoices of the product are not presented,
- If the informations on the documents of the installation, start or maintenance has been destroyed or changed,
- If the paid annual or the contractual periodic maintenance of the product has not been done on time by the authorized personnel,
- If unoriginal spare parts have been used,
- Notifications to our authorized services under the warranty period about the malfunctions that could not have been repaired, will make the time-out of the warranty stop only for that specific malfunction. In this case, the authorized service will inform about the compensation or the non-troubleshooting and the expanded warranty period will end in 3 months in any cases,
- Parts that may have possible abrasion in time such as mouldings, gas burners, lids, adjustment knobs, flame holder thermocouples etc. Will be repaired or changed with a fee.
- Damages caused by the unnecessary loss of time, the maleficence, the revenue loss, or the conduction of the product from the defective location to another,
- Malfunctions of the product due to squalidity are not covered by the warranty,
- The methods to be followed about the fault detection and elimination are determined completely by MUTAŞ's technical service management and the service matter is taken as basis for the determination of the malfunction.

AUTHORIZED SERVICE START-UP PAGE

Start Up Page

- The model and serial number of your device are shown on the “Technical Data” label affixed to the device.
- Select the technical data according to the device model on the nameplate.

MUST BE FILLED BY AUTHORIZED SERVICE!

COMPANY INFORMATIONS	:	
PRODUCT	:	
MODEL	:	
SERIAL NUMBER	:	
PRODUCTION DATE	:	
SERVICE STAMP AND SIGNATURE	:	
PERSONNEL OF THE SERVICE	:	
CONTACT		
PHONE	:	0312 837 76 72
FAX	:	0312 837 73 38
E-MAIL	:	teknikservis@vitalmutfak.com

CONTACT

MUTAŞ ENDÜSTRİYEL MUTFAK SANAYİ TİCARET ANONİM ŞİRKETİ
HEADQUARTER

ADRESS: Plevne Cad. No:40 Gülveren / ANKARA

PHONE: (0312) 363 99 33 FAX: (0312) 363 94 92

Web: www.vitalmutfak.com E-Mail: info@vitalmutfak.com

MUTAŞ ENDÜSTRİYEL MUTFAK SANAYİ TİCARET ANONİM ŞİRKETİ
FACTORY

ADRESS: Taşpınar Mahallesi Küme Evleri No:154/A 06760
Çubuk / ANKARA-TURKEY

PHONE: (0312) 837 76 72 FAX: (0312) 837 73 38

Web: www.vitalmutfak.com
E-Mail: info@vitalmutfak.com

AFTER SALES SERVICE

For the nearest MUTAŞ/VİTAL Authorized Service, please
contact the numbers above.

info@vitalmutfak.com

